



SIP aware Wireless Mesh Networks

- Military*
- Mining*
- Public Safety*

Francis da Costa, CTO, Meshdynamics

*Wireless for the **Outdoor Enterprise**TM*

What if

- Limited Carrier Service available ?
- Limited Internet service easily available ?

Scenarios:

- Rural Areas
- Developing countries
- Outdoor enterprises e.g. mining, military
- Disaster recovery situations.

Proposal: Extend FMC coverage with Mesh

- Mesh uses limited resources efficiently
- Larger areas connected economically



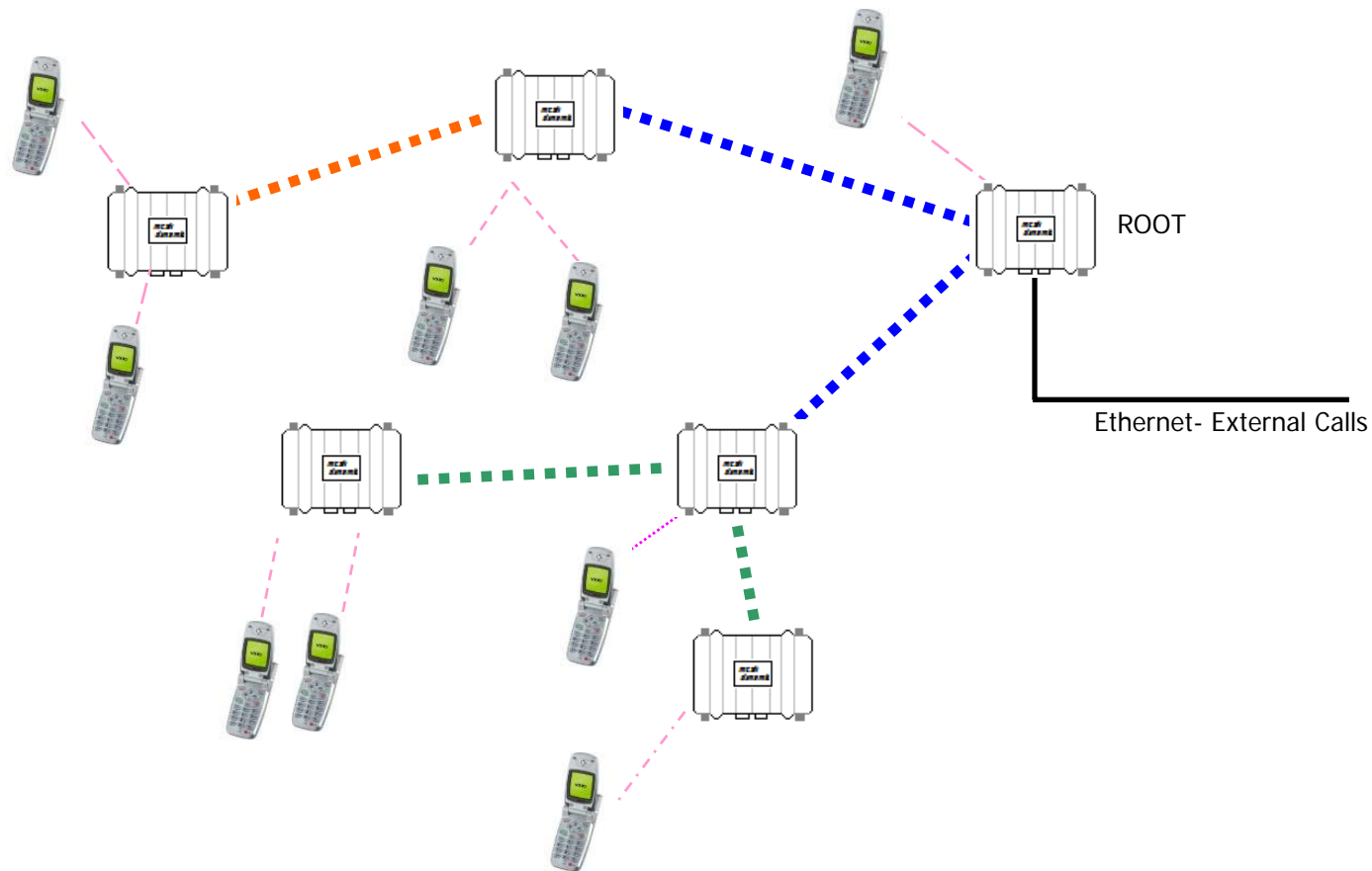

Mesh networks are self forming, self healing networks.

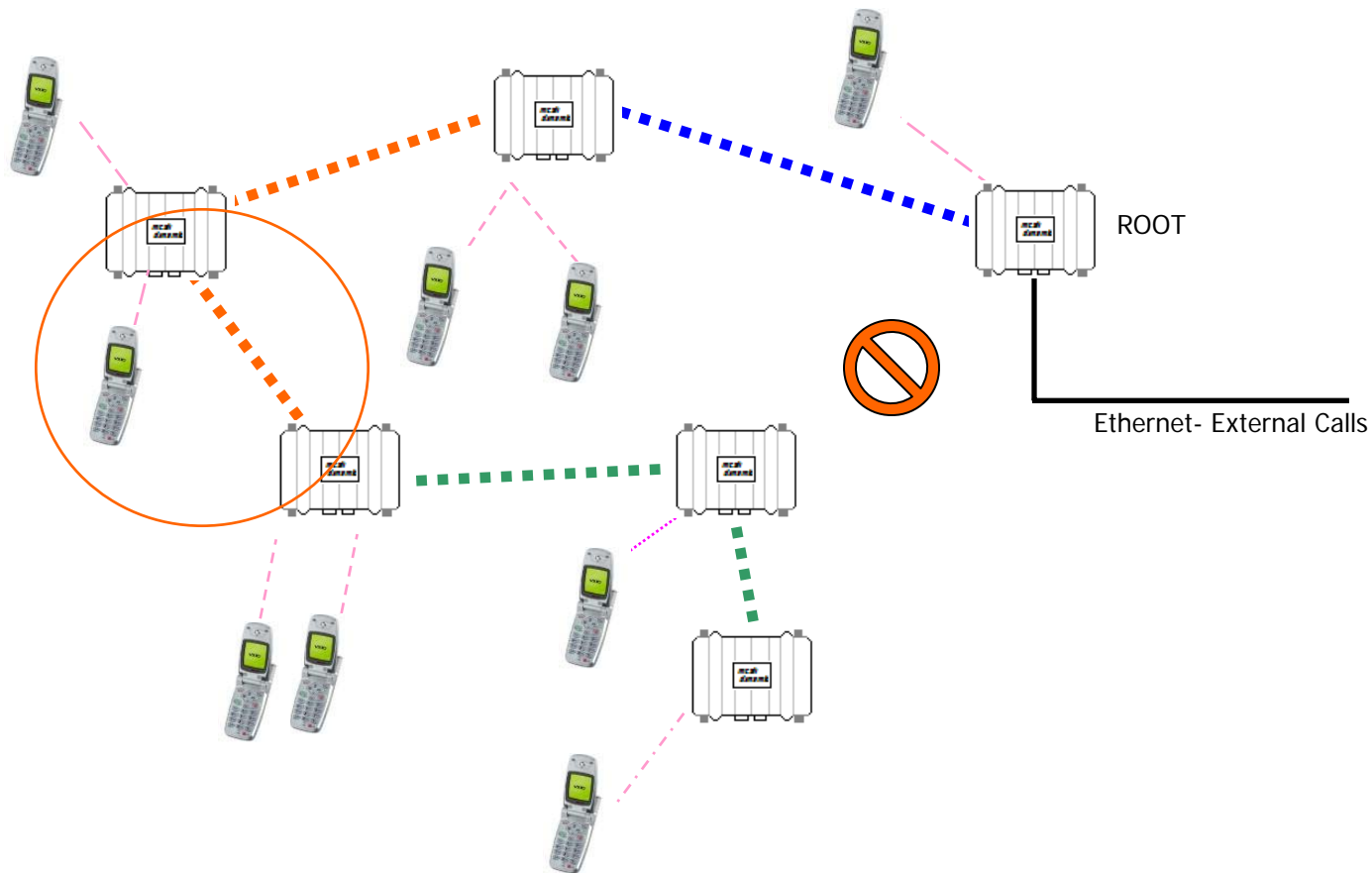

Mesh networks are self forming, self healing networks.

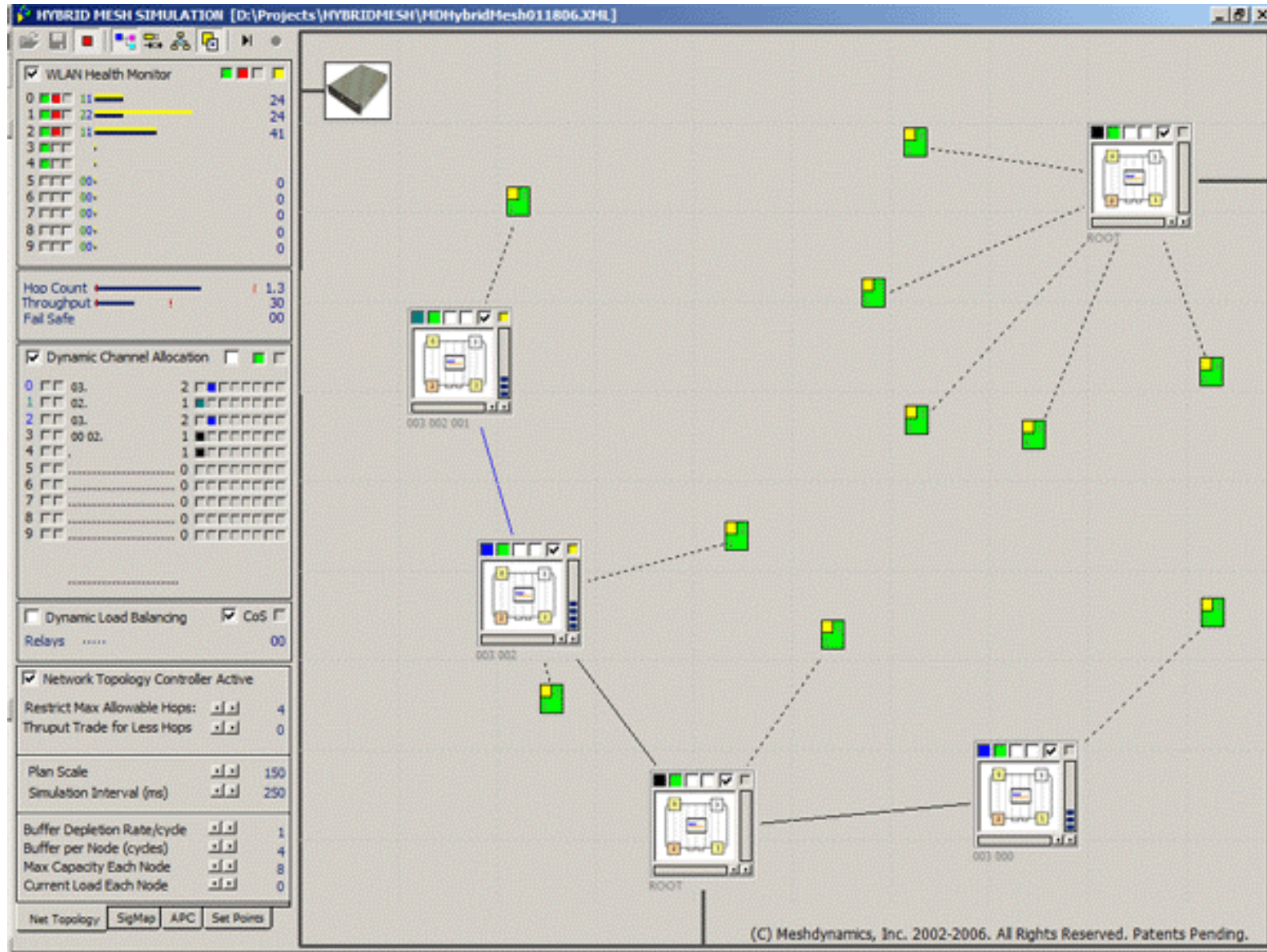

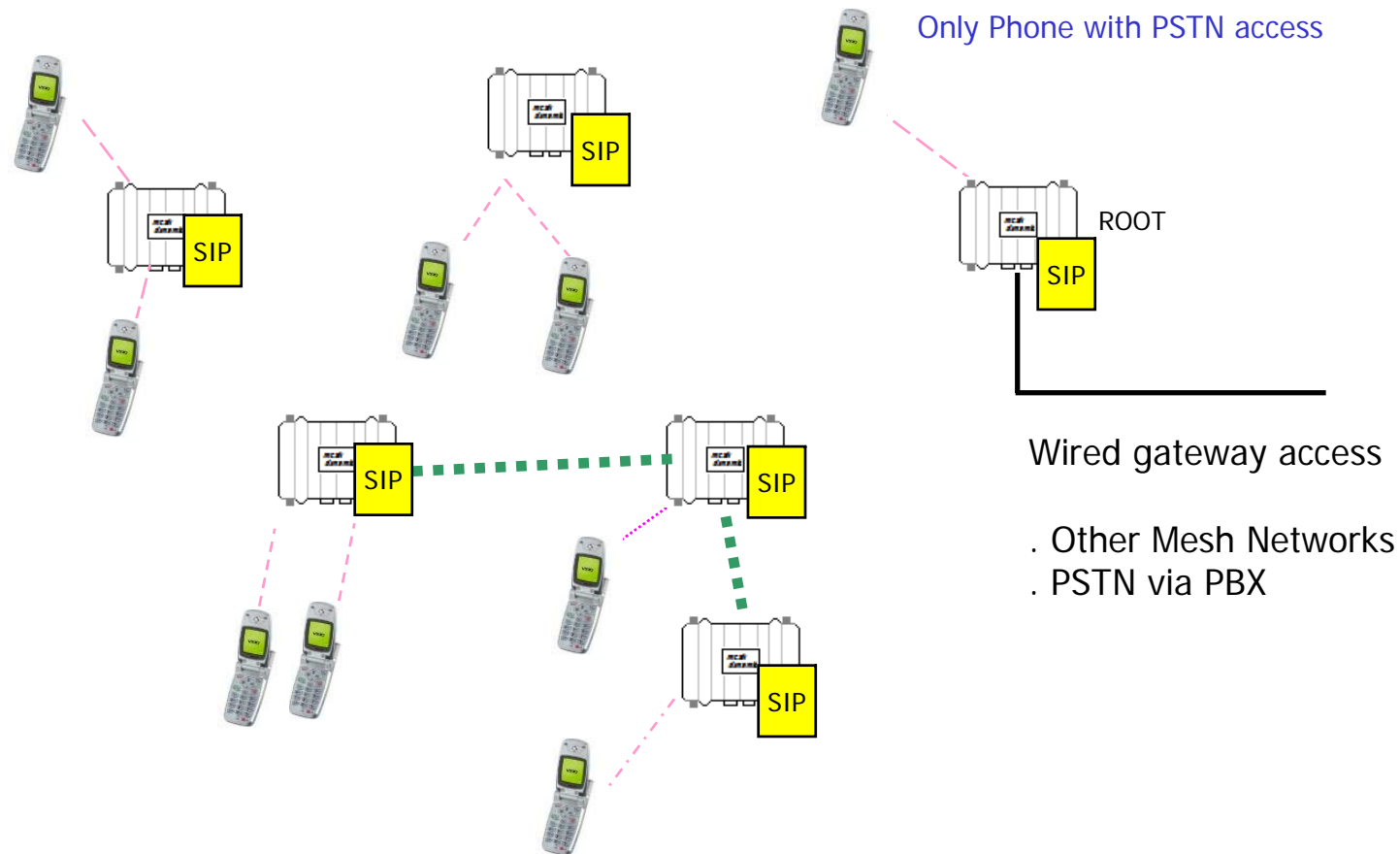

- Mesh routing software in node updates client/node routing tables.
- Client/node information stored based on MAC ID.
- For SIP phones the nodes also maintain Client Phone # to MAC ID look up.

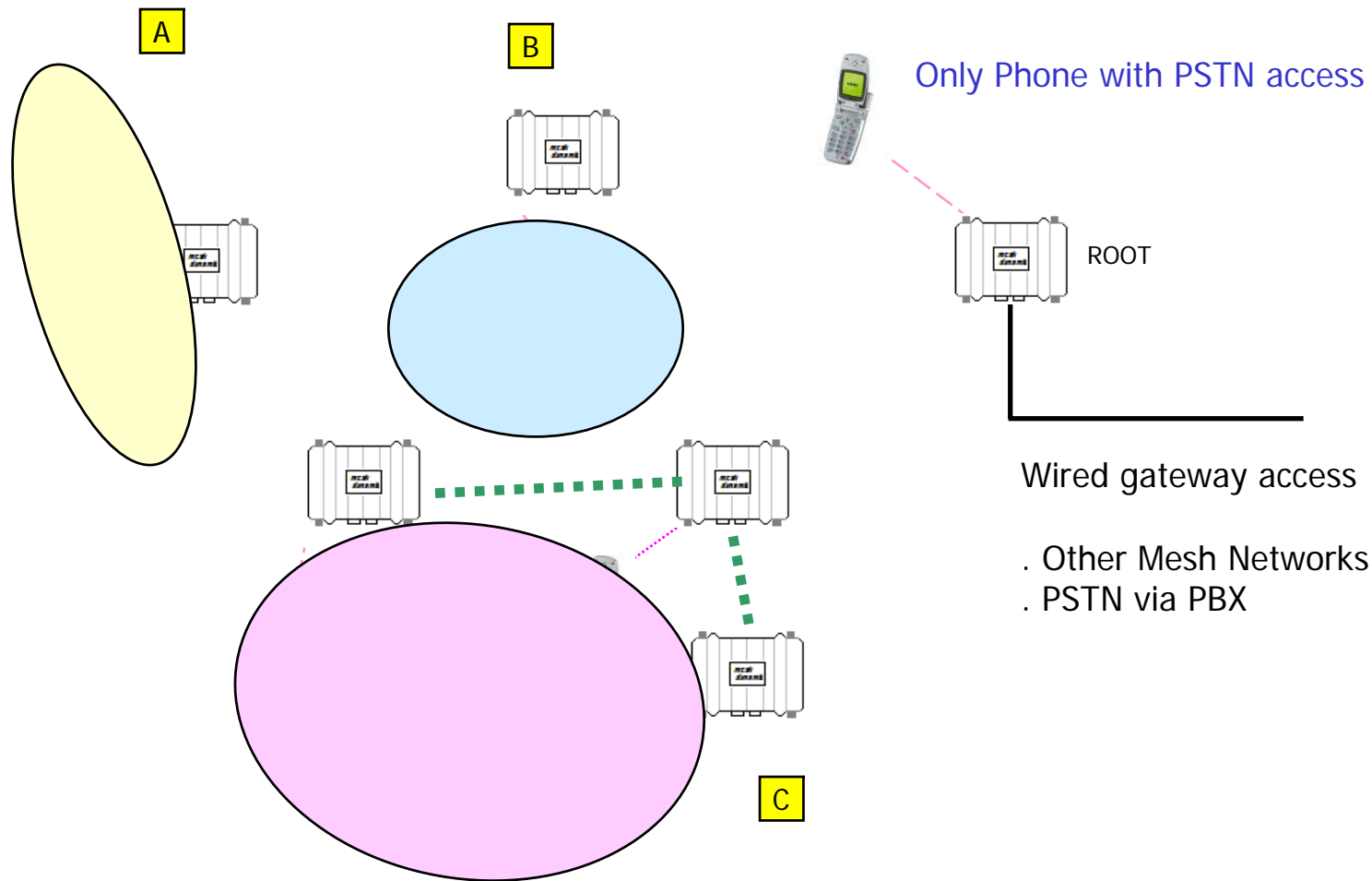

A , **B** Islands - client connectivity limited to clients of one node

C Floating Network - client connectivity limited to clients of connected nodes, no external connection available, no connectivity to other nodes in network

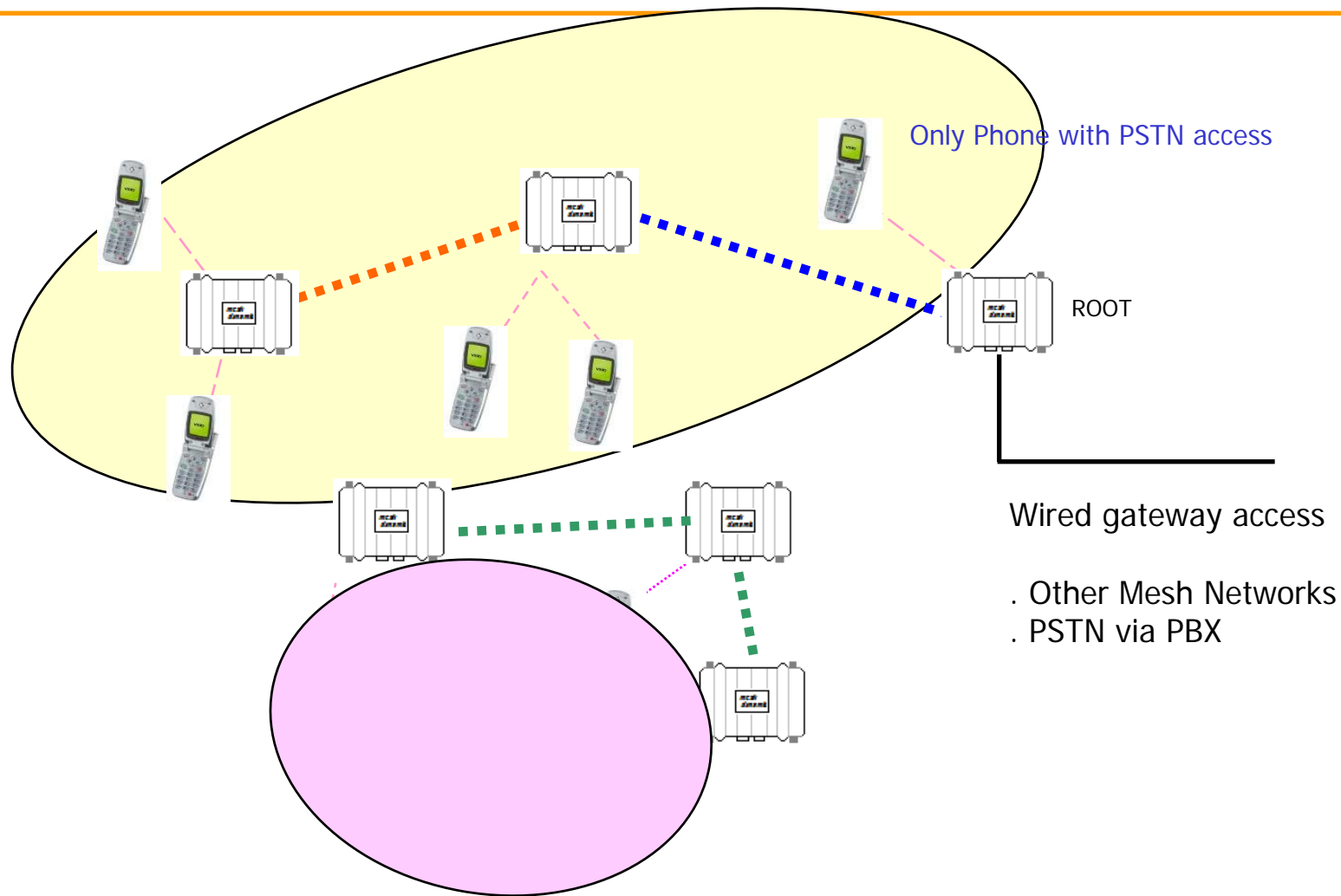

- As Mesh clusters coalesce, SIP registry is updated.
- Client communication range and accessibility increases. .

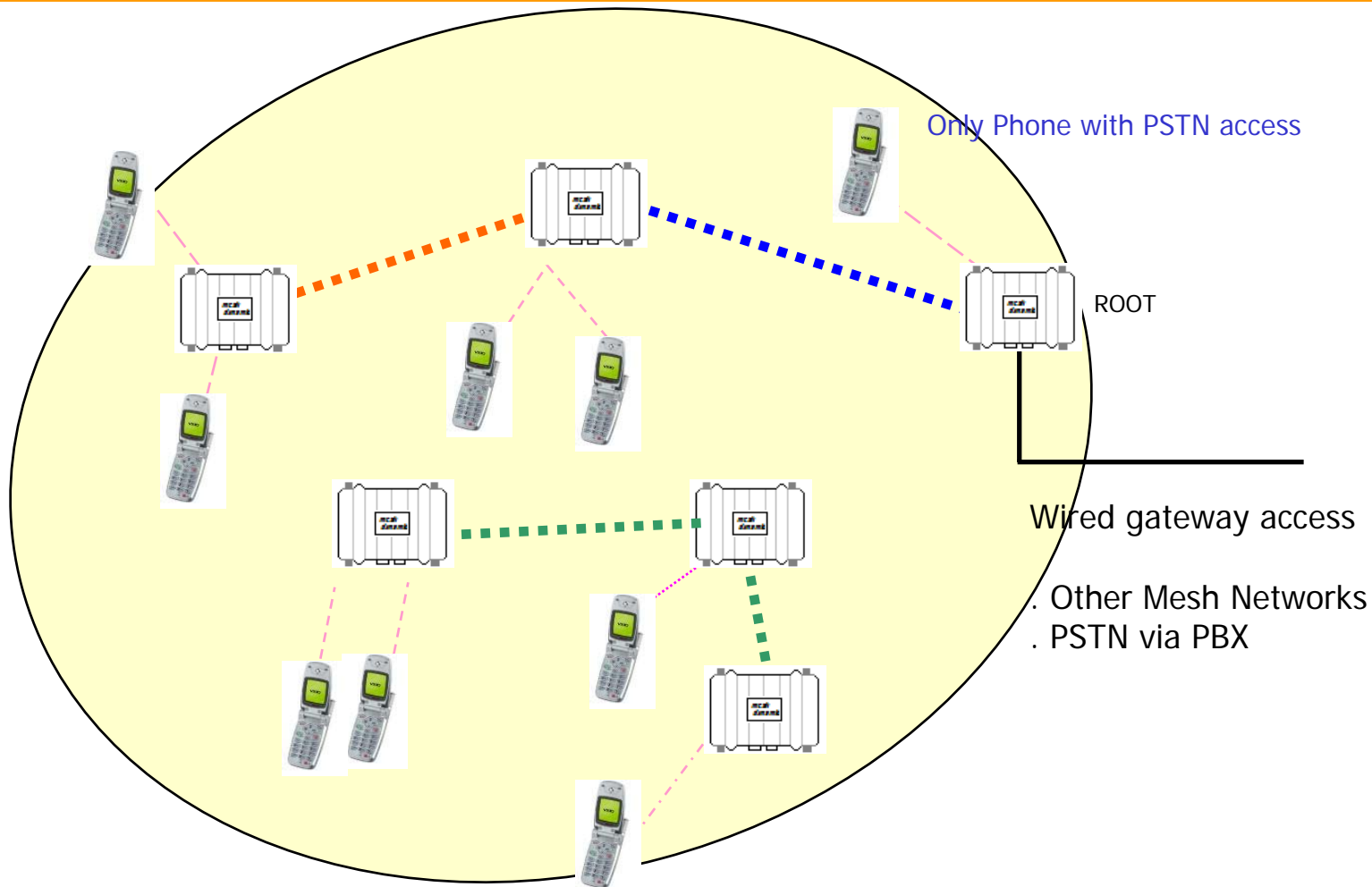

- As Mesh clusters coalesce, SIP registry is updated.
- Client communication range and accessibility increases.
- PSTN access also if any one mesh node has wired gateway access.

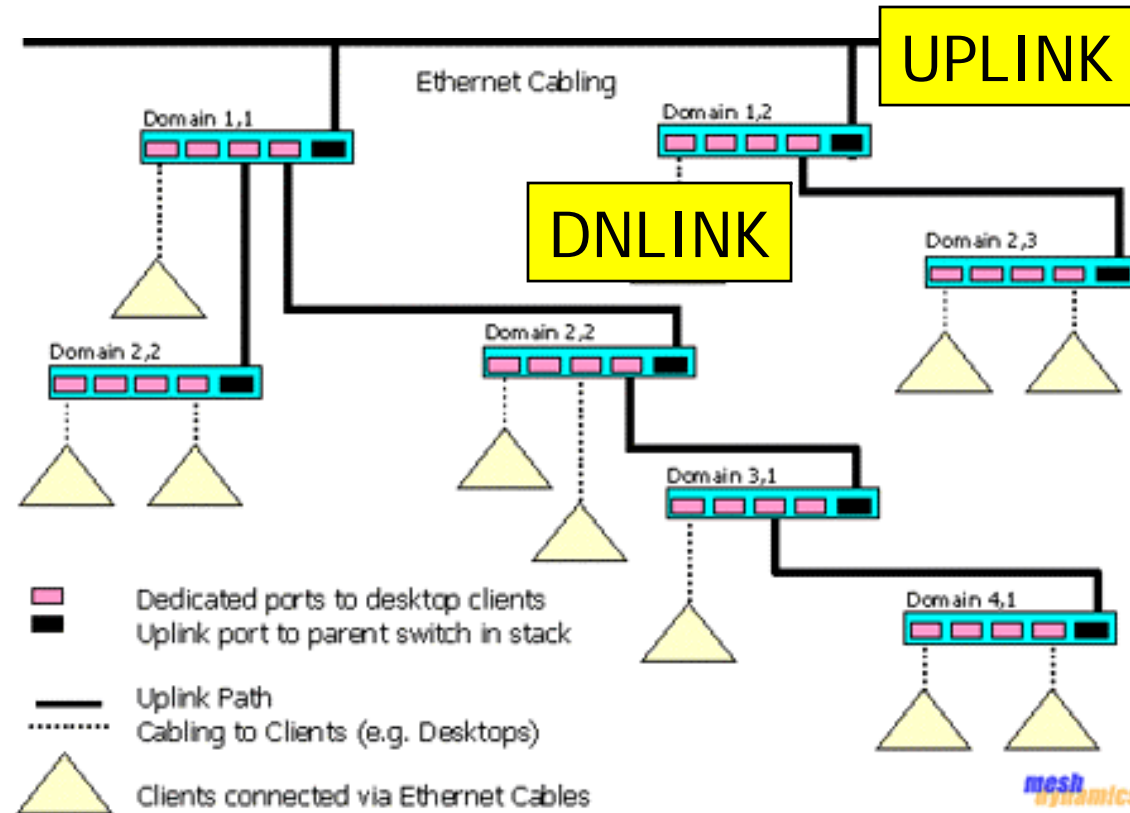

➔ LOW LATENCY, SCALABILITY BECAUSE

- Contention domains are kept separate with uplink and downlink.
- Tree structure obviates loops. Simpler routing table structure
- Faster updates $O(n)$ vs. $O(n^2)$ for non tree network structures.

Emulating the Wired Switch Stack Concept

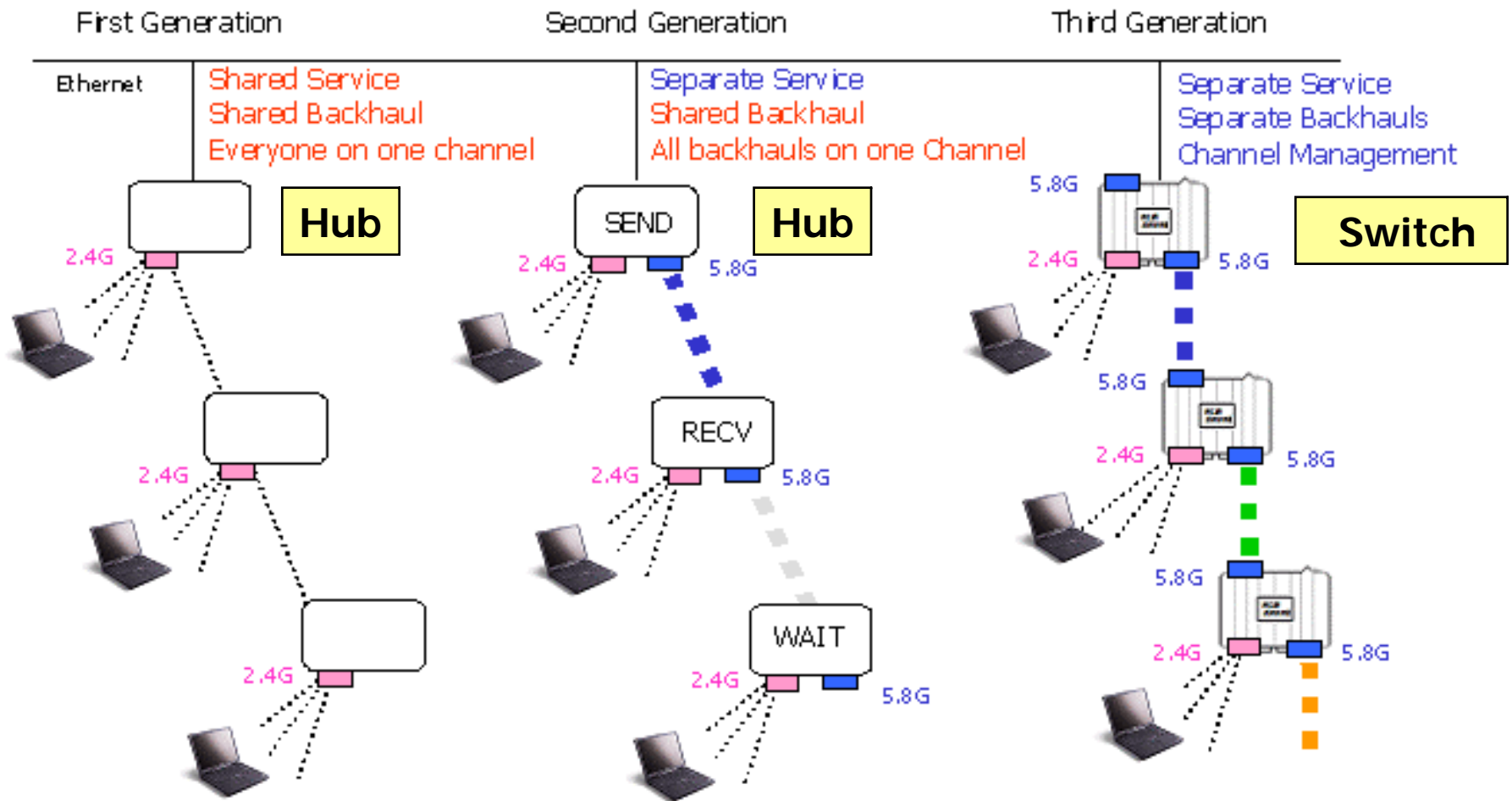

- . Wireless Emulation of wired uplink, downlink
- . Dynamic Radio Management manages “insulation”.

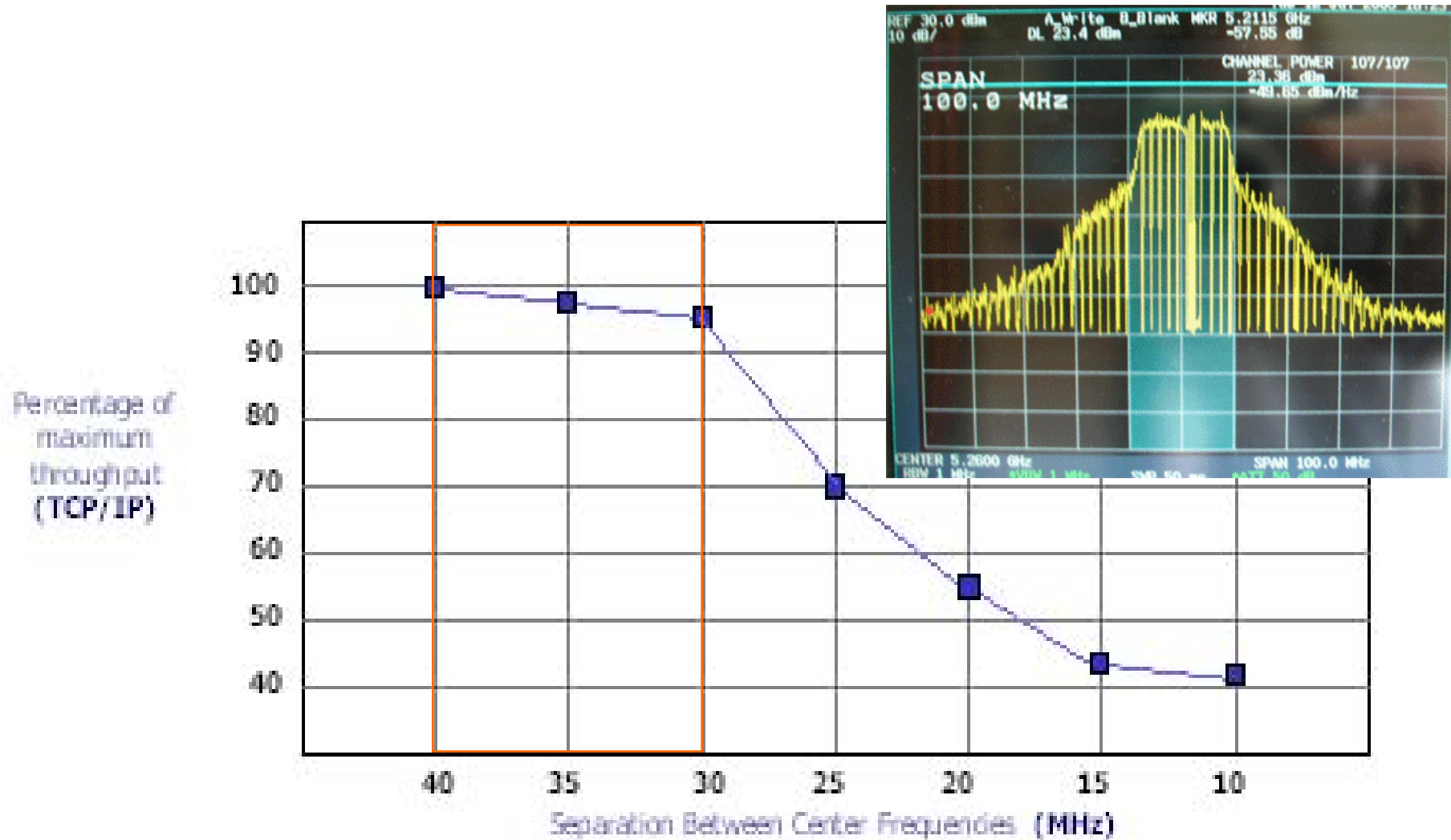

Dynamic Channel Management manages “insulation”.

Bandwidth Degradation over multiple hops of 1-Radio Mesh Backhuls

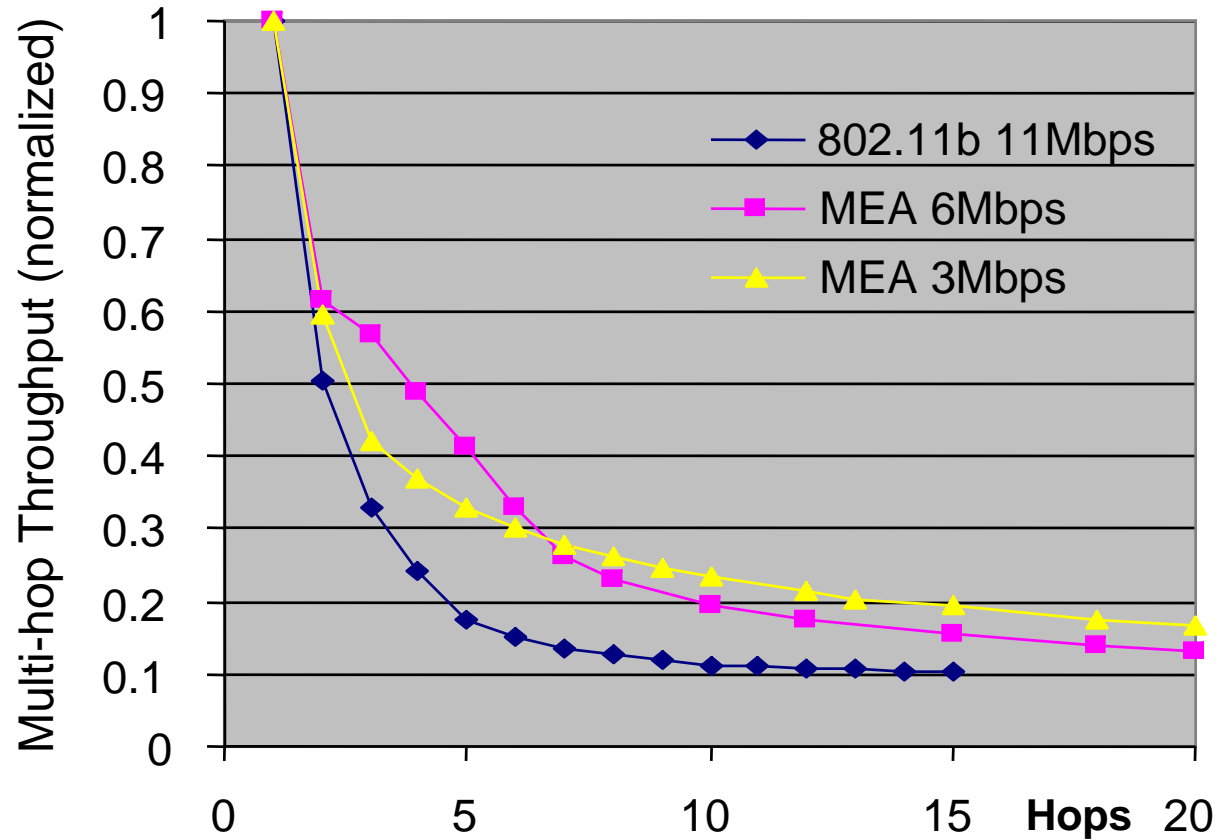

Source: Motorola® Presentation by Rick Rotondo, Oct 20, 2004, San Francisco

Bandwidth Degradation over multiple hops of 2-Radio Mesh Backhuls

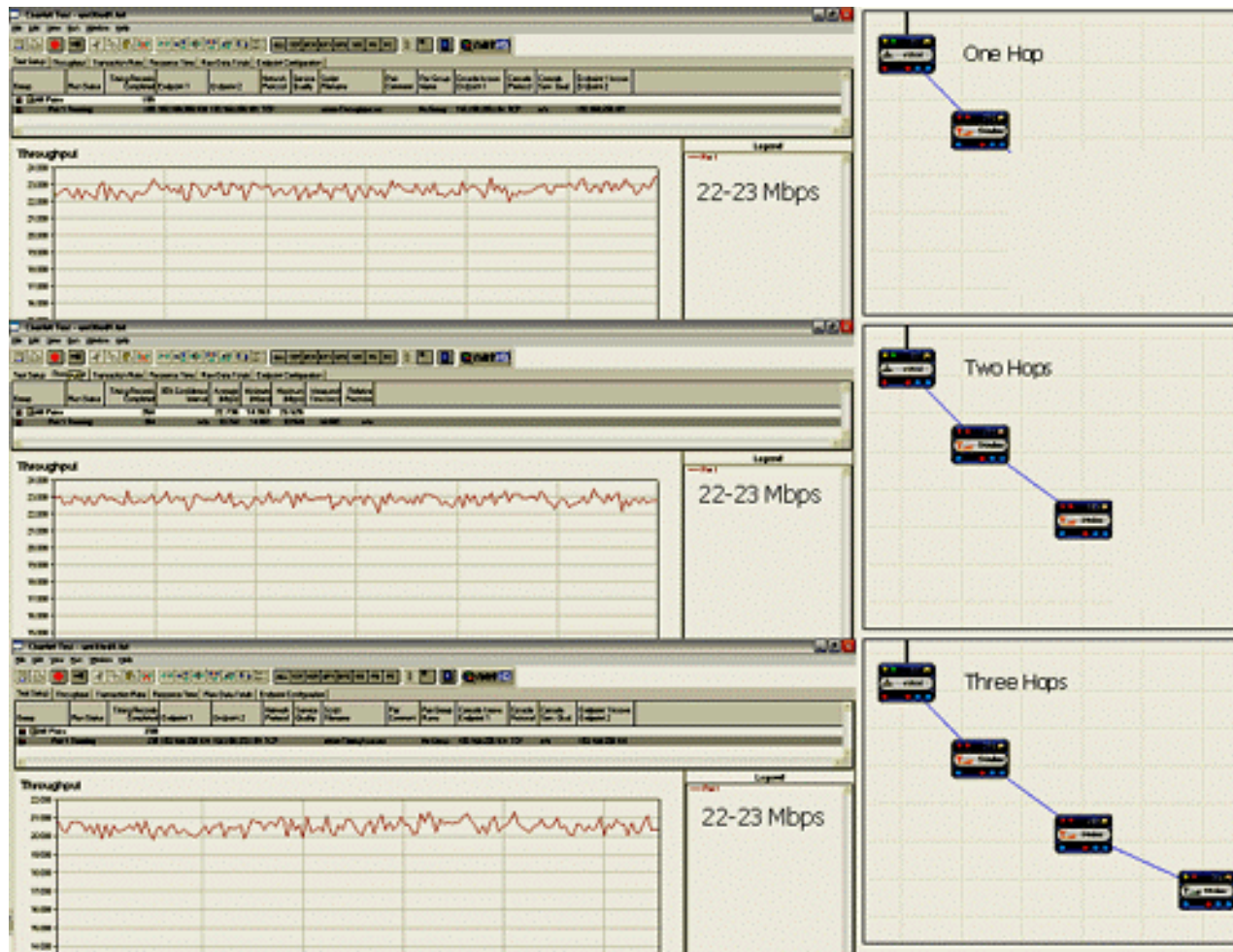

Backhaul bridge latency typically less than 1 ms. Tested over 18 hops.

```

eclipse.exe Secur...
C:\WINDOWS\System32\cmd.exe - ping 192.168.250.101 -t
Reply from 192.168.250.101: bytes=32 time=1ms TTL=128
Reply from 192.168.250.101: bytes=32 time=1ms TTL=128
Reply from 192.168.250.101: bytes=32 time=1ms TTL=128
Reply from 192.168.250.101: bytes=32 time=1ms TTL=128
Reply from 192.168.250.101: bytes=32 time=1ms TTL=128
Reply from 192.168.250.101: bytes=32 time=1ms TTL=128
Reply from 192.168.250.101: bytes=32 time=1ms TTL=128
Reply from 192.168.250.101: bytes=32 time=1ms TTL=128
Reply from 192.168.250.101: bytes=32 time=1ms TTL=128
Reply from 192.168.250.101: bytes=32 time=1ms TTL=128
Reply from 192.168.250.101: bytes=32 time=1ms TTL=128
Reply from 192.168.250.101: bytes=32 time=1ms TTL=128
Reply from 192.168.250.101: bytes=32 time=1ms TTL=128
Reply from 192.168.250.101: bytes=32 time=1ms TTL=128
Reply from 192.168.250.101: bytes=32 time=1ms TTL=128
Reply from 192.168.250.101: bytes=32 time=1ms TTL=128
Reply from 192.168.250.101: bytes=32 time=1ms TTL=128
Reply from 192.168.250.101: bytes=32 time=1ms TTL=128
Reply from 192.168.250.101: bytes=32 time=1ms TTL=128
Reply from 192.168.250.101: bytes=32 time=1ms TTL=128

```

- Intended for *asynchronous* not *isochronous* networking.
- Poor latency and jitter control , degrades with more clients

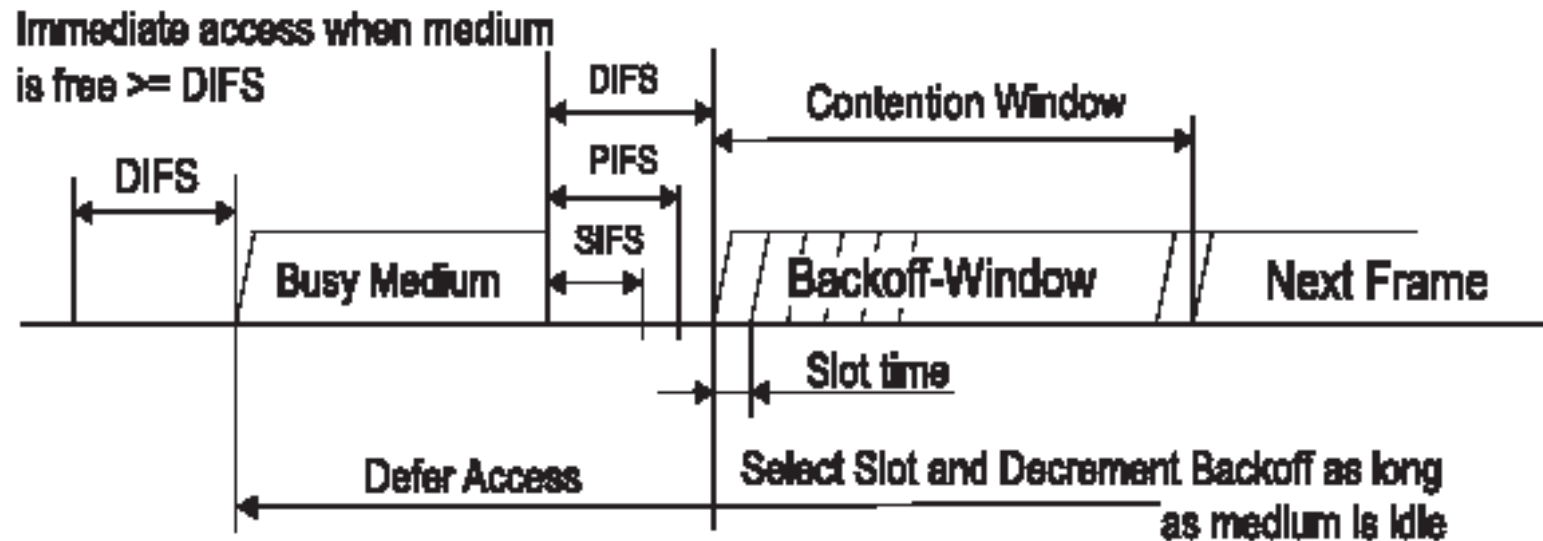
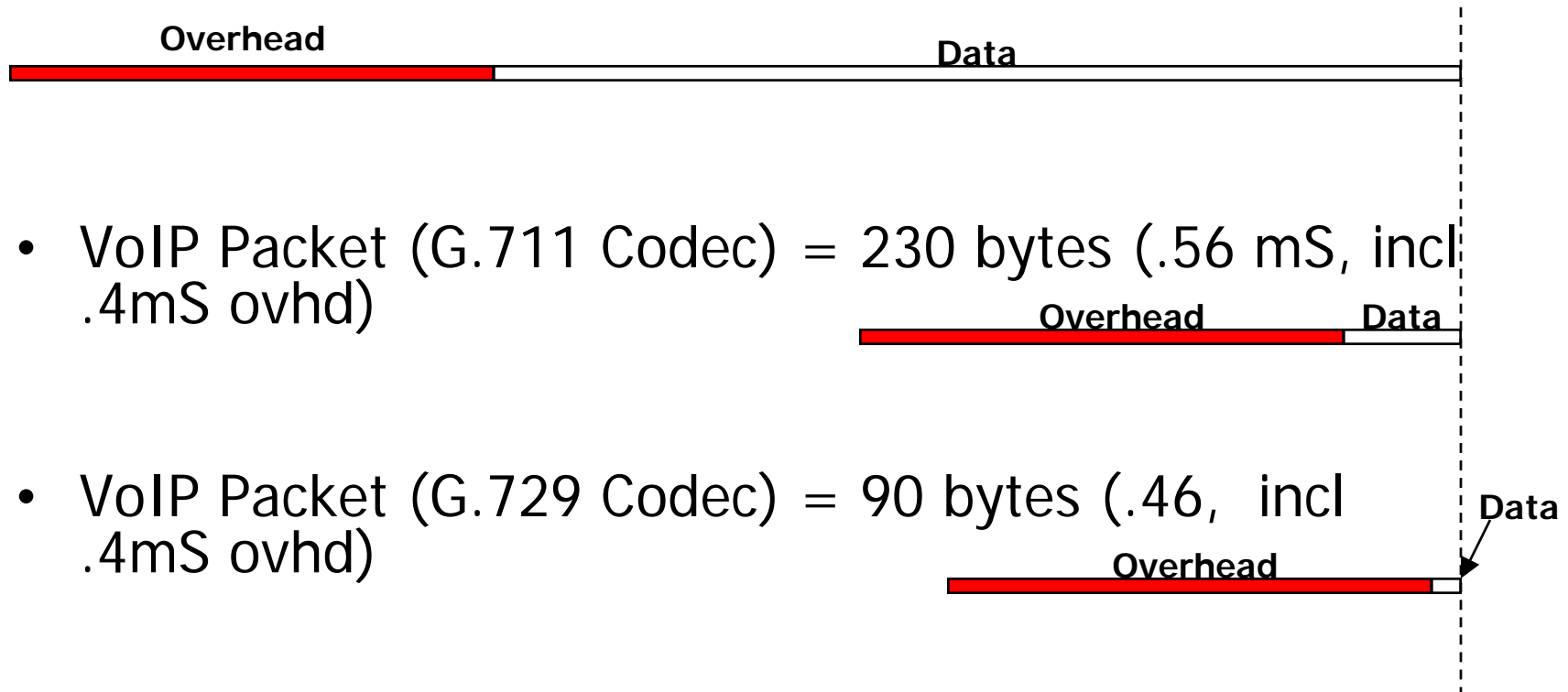

Figure 51—Basic access method

- Backhaul must contain jitter and latency over multiple hops
- Access Point software should help remove contention at the source

- Typical Data Packet = 1500 bytes (1.44mS, incl .4mS ovhd)



- VoIP Packet (G.711 Codec) = 230 bytes (.56 mS, incl .4mS ovhd)

- VoIP Packet (G.729 Codec) = 90 bytes (.46, incl .4mS ovhd)

- *Backhaul must contain jitter and latency over multiple hops*

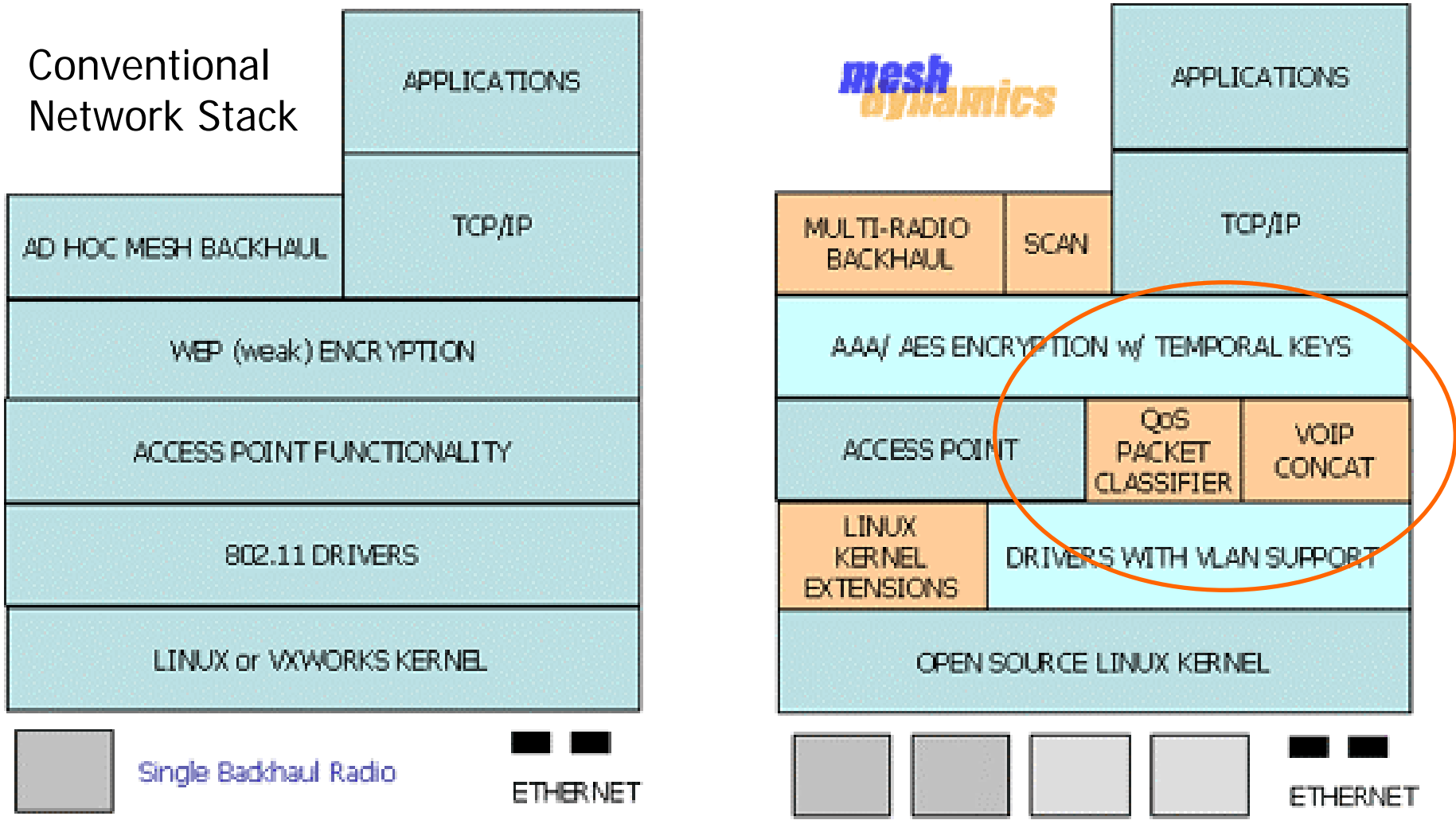

Bulk transport "bus" leaves each node every 20 ms (adjustable)

One-Way Delay

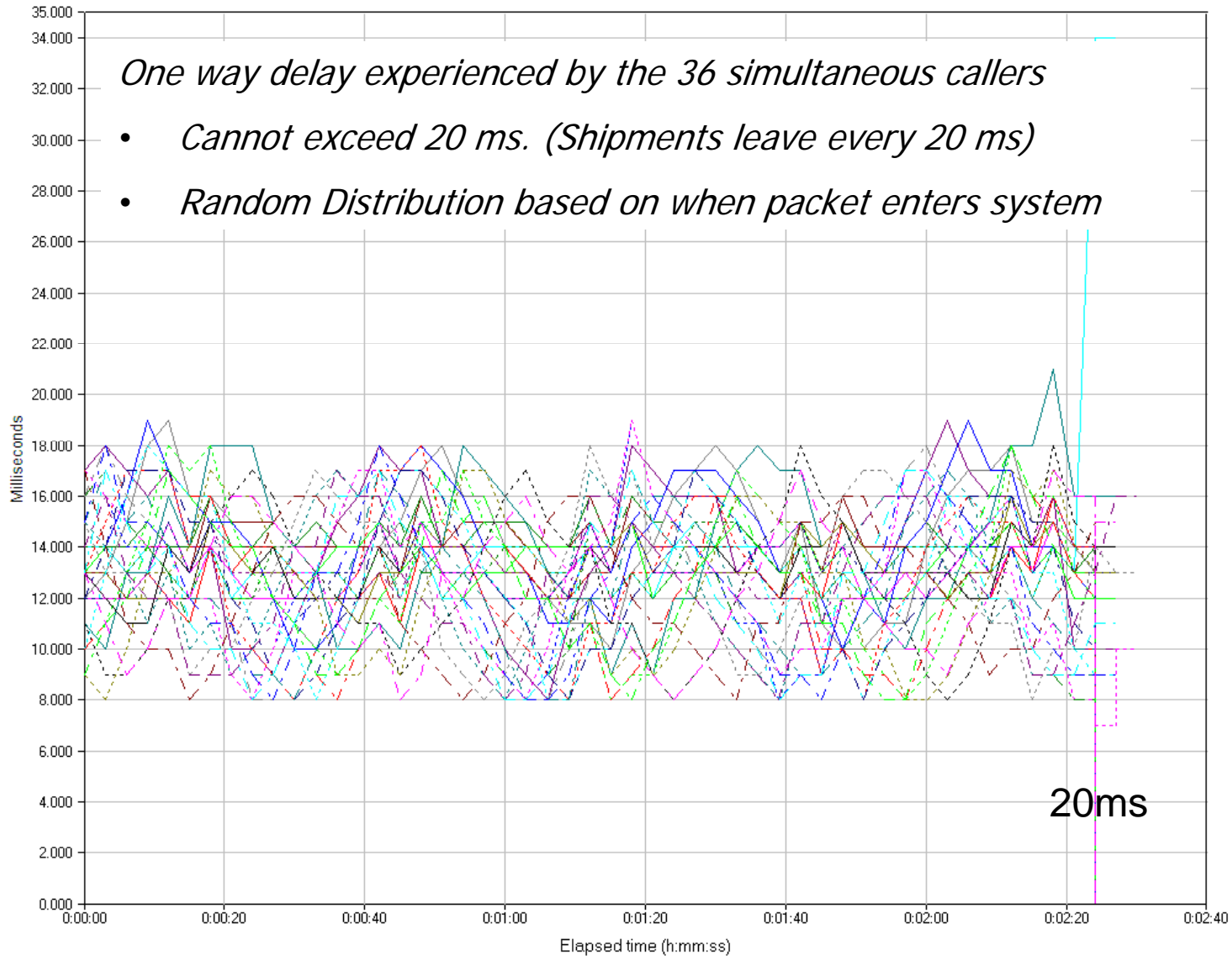

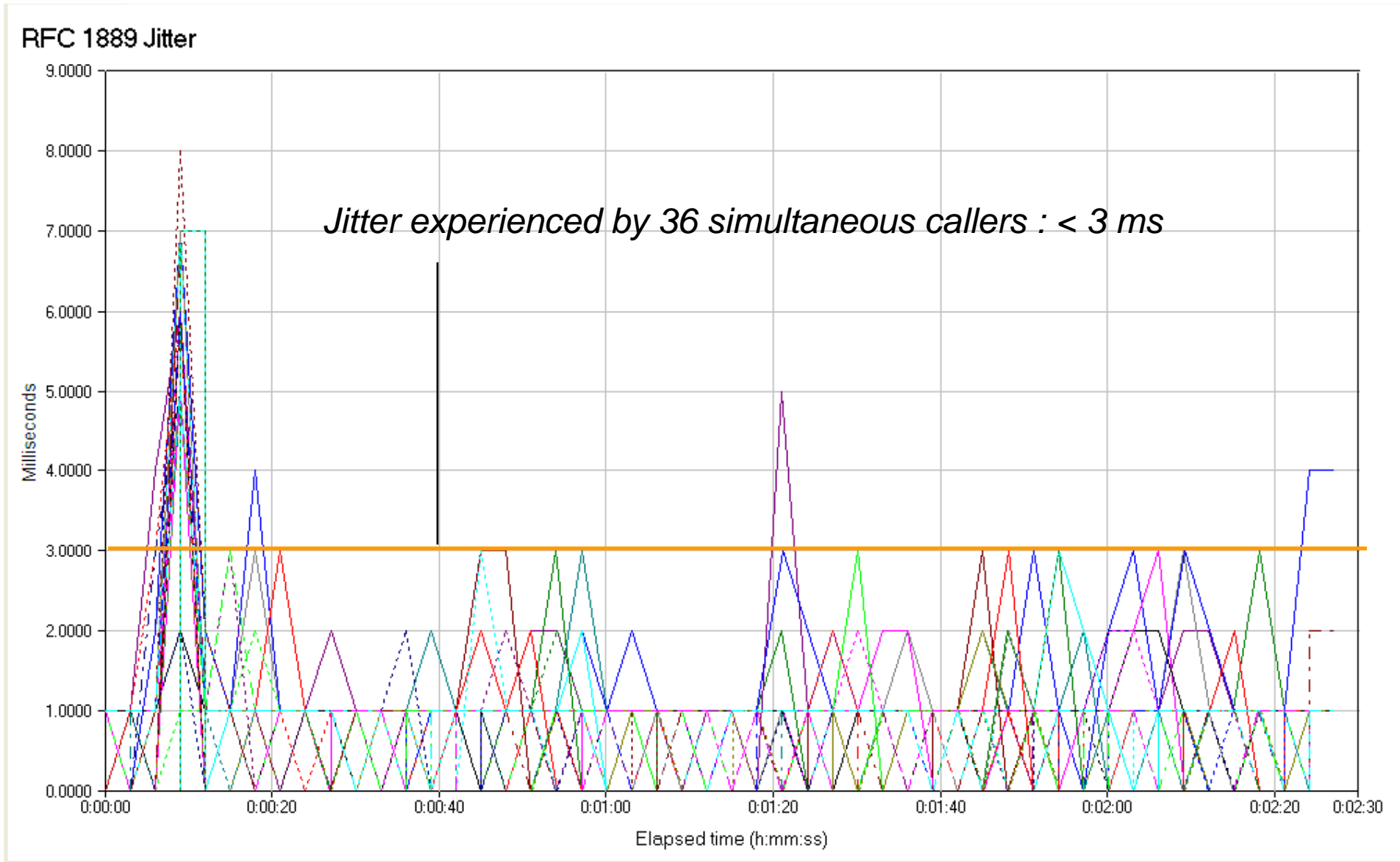

Concatenation Performance Results- Satisfaction

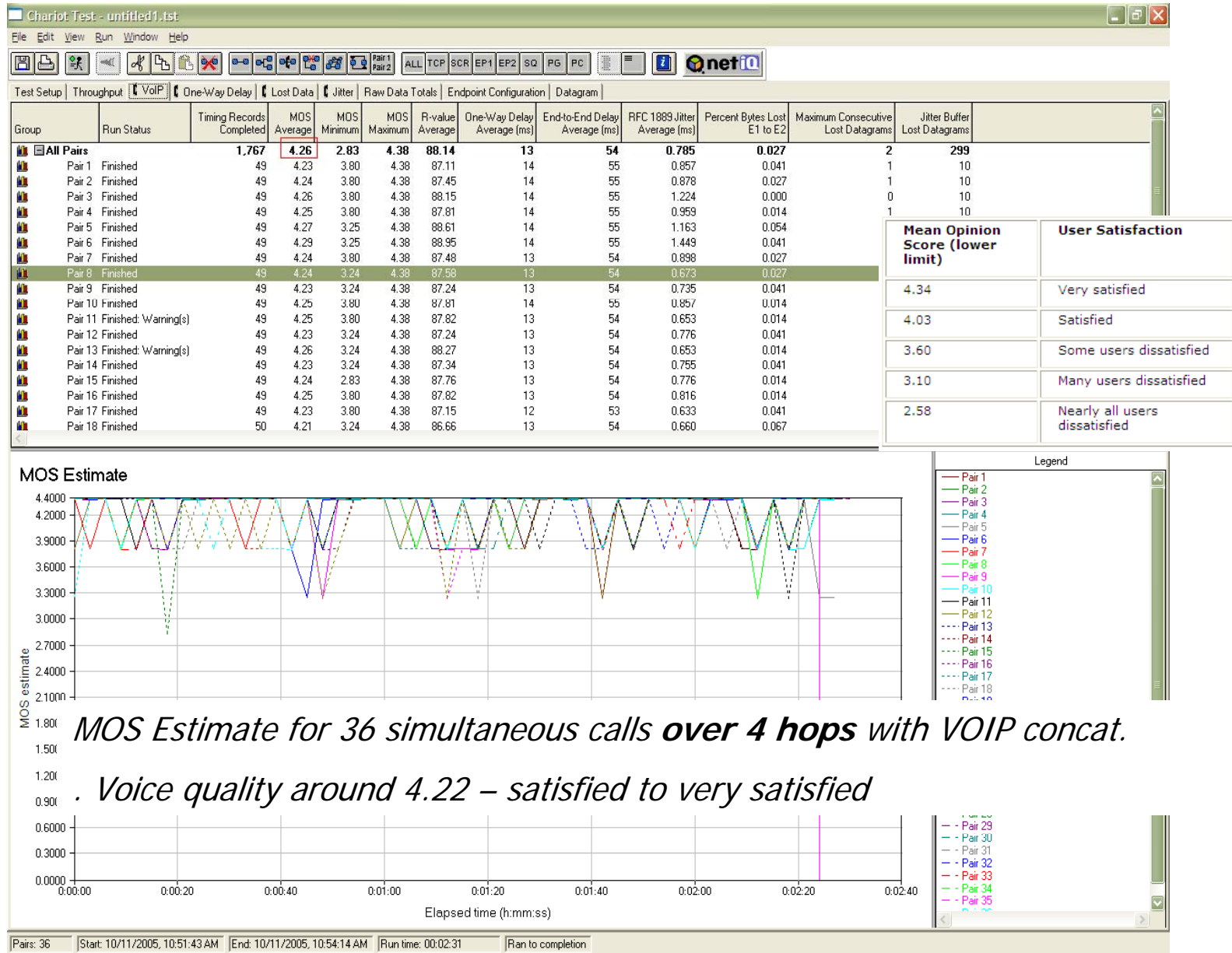

Francis da Costa, CTO, Meshdynamics

Phone: (408) 373 – 7700

Email : fdacosta@meshdynamics.com

*Wireless for the **Outdoor Enterprise**TM*